

# User's Manual

## PRP-085III THERMAL RECEIPT PRINTER

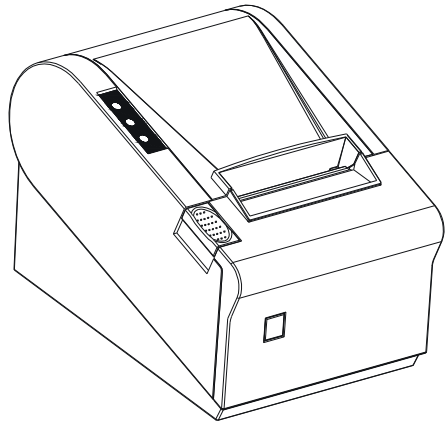

*Specifications subjects to  
change without notice*

# Contents

---

<b>1. General Information</b>	
1.1) Main Features.....	2
1.2) PRP-085III Function List.....	3
<b>2. Quick Start</b>	
2.1) Unpacking & Parts Identification.....	4
2.2) Loading the Paper Roll.....	5
<b>3. Printer Interface and Connection</b>	
3.1) Connecting the Interface Cable.....	8
3.2) Connecting to a Cash Drawer.....	8
3.3) Connecting the AC Adapter.....	9
<b>4. Configuration</b>	
4.1) Panel LED indicators.....	10
4.2) DIP Switch Settings.....	11
4.3) Printer Self Test.....	12
4.4) Driver Installation.....	12
<b>5. Safety and Maintenance</b>	
5.1) Safety Information.....	14
5.2) Periodical Cleaning.....	14
5.3) Preventing Paper Jams.....	14
5.4) Fixing Paper Jam.....	15
<b>6. Appendix</b>	
- Product Specifications.....	16
- Configuration.....	19
<b>7. General Printer Commands.....</b>	<b>24</b>

# 1. General Information

## Models

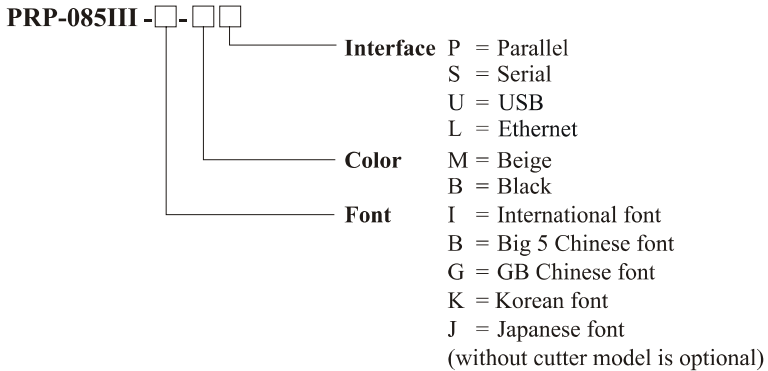

Note: International font can be combined with others, for example  
PRP-085III-BI-MS, Big5+International, beige, serial

## 1.1) Main Features

### 1. High speed printing:

- 220 mm/s maximum print speed.
- Low-noise thermal printing.
- High reliability due to a stable mechanism.

### 2. Application Software:

- Command protocol is based on the ESC/POS standard.
- Various Layouts are possible by using page mode.
- Characters can be scaled up to 64 times as large as the standard size.
- Smoothing is also possible.
- Repeated operation and copy printing are possible by using macro definitions.
- Character font size (12×24 font or 9×17 font) can be selected using a command.

### **3. Printer Handling:**

- Easy paper-roll installation.
- Equipped with an auto cutter.
- The printer allows easy maintenance for tasks such as head cleaning.
- Two different print densities can be selected by DIP switches.
- The built-in interface provides control capability for one cash drawer.

## **1.2) PRP-085III Function List**

1. Maximum printing speed 220mm/sec (576 dots)
2. Fully-compatible with EPSON ESC/POS commands ( See PRP-085III command sets for programming reference )
3. Characters can be scaled up to 8 times larger than standard size
4. Support transmit status
5. Support print data in page mode
6. Support Font A (12\*24) and Font B (9\*17) characters
7. Support NV Image Download
8. Three indicator LEDs ( POWER, ERROR, and Paper roll out ) and One Panel button ( FEED )
9. Support warning beep sound
10. Support dip switch to select Chinese / ASCII mode
11. Support printer server printing
12. Support 9600, 19200, 38400, 115200 bps baud rate
13. Support print with 90° rotation

# 2. Quick Start

## 2.1) Unpacking & Parts Identification

### a. Unpacking:

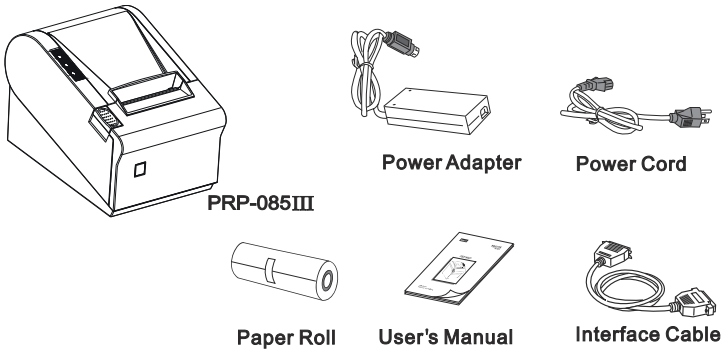

### B. Parts Identification:

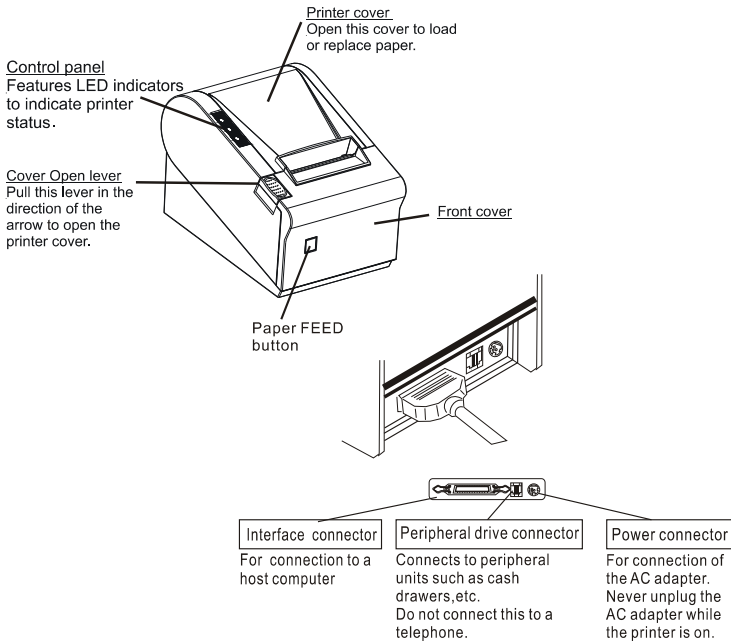

## 2.2) Loading the Paper Roll

- a. Make sure that the paper roll matches the printer's specification. Do not use paper rolls that have the paper glued to the core because the printer cannot detect the paper end correctly.

**Important:** *The printing quality and lifespan of the thermal head cannot be guaranteed if any paper other than that recommended is used. Thus, the warranty will be void automatically if any fault occurs due to the use of wrong paper rolls.*

### Recommended Paper Rolls

Part Number	Manufacturer
HPK-110	Hansol Patech Co. Ltd.
AF50KS-E	JUJO Paper Co. Ltd.
TF-50KS-E	Nippon Paper Industries Co. Ltd.
PD-160R	New Oji Paper Mfg. Co. Ltd.
F380	Nansaki Specialty Papers Inc.

- b. Open the paper roll cover by pressing the cover-open button

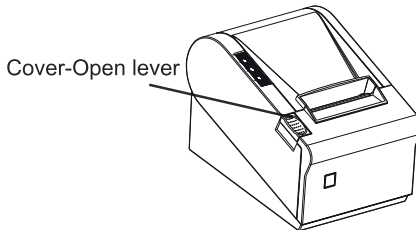

**Important:** *Do not pull the cover open lever and open the printer cover when printing is in progress.*

c. While observing the direction of the roll, set the paper roll into the hollow, and pull on the leading edge of the paper toward you as shown:

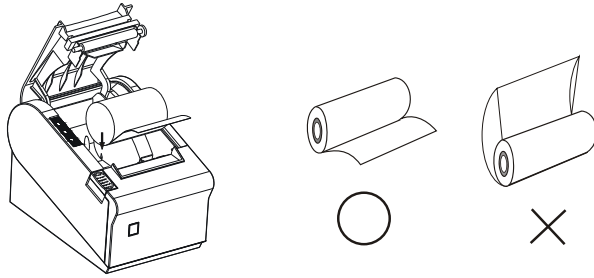

d. Close the cover: When closing the cover, press the center of printer cover firmly to prevent paper miss-loading

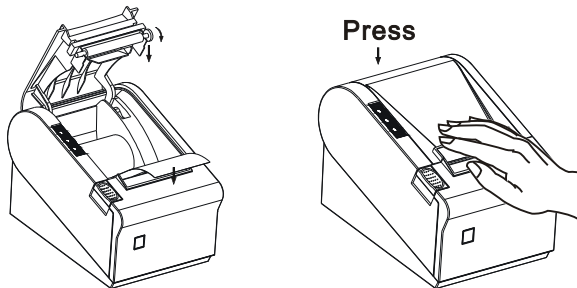

e. Tear off the paper outside the cover as shown.

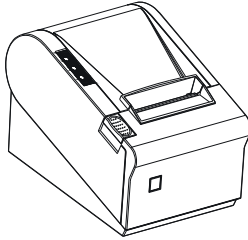

# 3. Printer Interface and Connection

## 3.1) Connecting the Interface Cable

- a. Before connecting/disconnecting the interface cable, make sure that power to the printer and all the devices connected to the printer is turned off.
- b. Connect the interface cable to the connector on the rear panel of the printer.
- c. In the case of a serial interface, tighten the connector screws. In the case of a parallel interface, fasten the connector clasps.

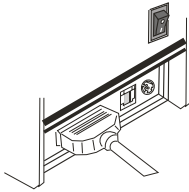

Plug the cable connector securely into the printer's interface connector.



Attach the other end of the cable to the computer

## 3.2) Connecting to a Cash Drawer

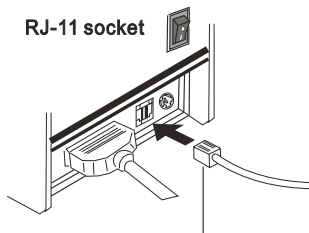

Connect the cash drawer's RJ-11 phone jack to the connector on the rear panel

**Important:**

- Make sure that the printer is turned off and unplugged from the AC outlet and that the computer is turned off before making connections.
- Do not connect a telephone line into the peripheral drive connector. Failure to observe this may result in damage to the printer.

### 3.3) Connecting the AC Adapter

- a. Connect the AC power cord to the inlet of AC adapter, and then connect the power cord plug to a suitable electrical outlet.
- b. Connect the adapter cable to power connector of printer; make sure the printer power switch is OFF before making any connections.

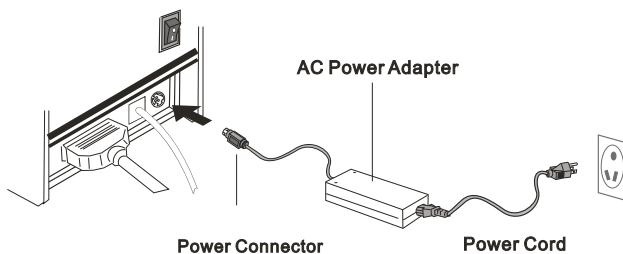

***CAUTION:***

***DO NOT USE ANY AC POWER ADAPTERS OTHER THAN SPECIFIED.***

- c. Set the power switch as shown. The POWER lamp on the control panel will light up.

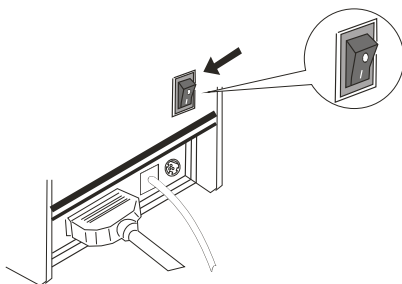

## 4. Configuration

### Printer Control Panel & Status Indication

#### 4.1) Panel LED indicators

1. Power (POWER) LED: Green  
On: Power is stable  
Off: Power is not stable
2. Error (ERROR) LED: Red  
On: Off line (except during paper feeding using the FEED button and test printing, and the error state.)  
Off: Normal condition
3. Paper roll end (PAPER OUT) LED: Red  
On: The paper roll near end is detected.  
Off: Paper is loaded (Normal condition).

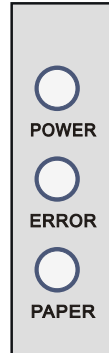

## 4.2) DIP Switch Settings

The DIP switch panel is located at the bottom of the printer as shown:



### DIP Switch Functions:

Switch	Function	ON	OFF	Default
SW-1	Select cutter	No	Yes	OFF
SW-2	Select beeper	Yes	No	OFF
SW-3	Print density	Dark	Light	OFF
SW-4	Two-byte character code	No	Yes	OFF
SW-5	Character per line	42	48	OFF
SW-6	Cutter with cash drawer	Yes	No	OFF
SW-7	Select Baud rate			OFF
SW-8	Select Baud rate			OFF

SW-7	SW-8	Baudrate(bps)
ON	ON	38400
OFF	ON	115200
ON	OFF	9600
OFF	OFF	19200

*Note: Before configure the DIP switch settings, please first turn the printer power off and remove the paper roll.*

(\*) Baud Rate is only available for serial interface models.

### 4.3) Printer Self Test

This is to test whether the printer is working properly or not and also checks the printing quality, firmware version, and DIP switch settings

1. Hold the FEED button first and then turn on the power at the same time, release the button after around 1 second.
2. If the printer is working properly, it should then automatically print the self-testing result that indicating the firmware version number, printer connection type, English alphanumeric characters, and few Taiwan fonts.
3. The test print will be ended with the following message:

**\*\*\* COMPLETED \*\*\***

*Note:* The above procedure does not test parallel or serial ports. Please use communication utility such as Windows HyperTerminal to test the printer connection.

### 4.4) Driver Installation

1. To install the PRP-085 III driver, please insert the bundled CD disk into the CD-ROM drive.
2. In the CD-Rom menu, please go to Receipt Printer > PRP-085 III and double click the SetupEN.exe file to begin the driver installation process and follow the installation instructions.

3. Please choose the OS that matches with your computer system and press Next.

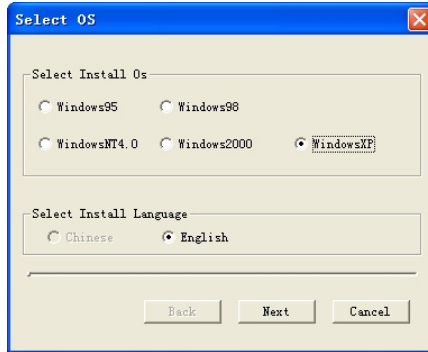

4. Please select PRP-085 III Series for Install Module. For Printer Port Setting, if you are connecting the printer to PC COM ports via RS-232 connection, the FlowControl must be set to Hardware. Press Finish when you done all the setting to end installation.

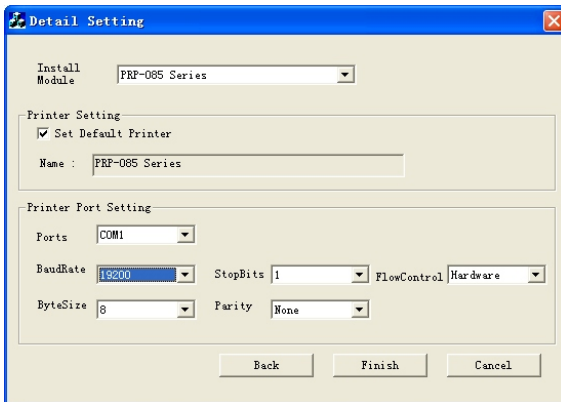

# 5. Safety and Maintenance

## 5.1) Safety Information

1. Do not touch the HEAD of printer with anything.
2. Do not touch the cutter blade.
3. Only use the power supply that is come along with the printer.
4. Do not bend the power cord excessively or place any heavy objects onto it.
5. When connecting or disconnecting the plug, always hold the plug- not the cord.
6. Keep the desiccant out of children's reach.
7. Use only approved accessories and do not try to disassemble, repair or remodel it for yourself.
8. Do not let water or other foreign objects in the printer.
9. Install the printer on the stable surface. -Choose a firm, level surface where the printer will not be exposed to vibration.
10. Do not use the printer when it is out of order. This can cause a fire or an electrocution.
11. Do not connect a telephone line into the peripheral drive connector.
12. We recommend that you unplug the printer from the power outlet whenever you do not plan to use it for long periods.

## 5.2) Periodical Cleaning

Printed characters may become partially unclear due to accumulated paper dust and dirt. To prevent such a problem, paper dust collected in the paper holder and paper transport section and on the surface of the thermal head must be removed periodically. Such cleaning is recommended to be carried out once six month or one million lines.

### a. Cleaning the Thermal Head

To remove blackish dust collected on the surface of the thermal head, wipe it with Isopropyl alcohol (IPA).

*Note: The thermal head is easy to damage, so clean it gently with a soft cloth. Take sufficient care not to scratch it when cleaning it.*

### b. Cleaning the Paper Holder

Use a soft cloth to remove paper dust from the paper holder and paper transport section.

## 5.3) Preventing Paper Jams

The paper should not be touched during printing. Shift the paper during paper ejection may cause a feed failure or paper jam.

## 5.4) Fixing Paper Jam

The Status LED (Red) on the printer control panel will flash with beeps if paper is jammed. Please follow the below instruction to remove paper jam.

- a. Switch the printer power off.
- b. Open the printer cover by pushing the Cover-Open button.
- c. If the printer cover opens, removed the jammed paper gently (**take care not to touch the printer head.**) And reinstall the paper roll.

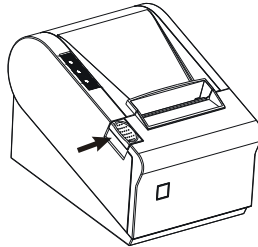

- d. **If the printer cover will not open**, please restart the printer by switching power off/on, and try again, if the cover is still unable to open please follow the instructions below:

1. Set the printer power OFF
2. Slide off the front cover to reveal the auto cutter
3. Roll the little gear as shown until the warning beeps is stopped.

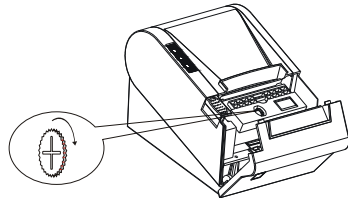

**CAUTION:**

*Since working on the cutter may be dangerous, be sure to turn off the printer first.*

**Note:**

*Do not apply extreme force to open the front cover to prevent damages to the cutter. If the front cover will not open properly, please contact your dealer.*

- e. Return the cutter to its home-position and release or clean out the jammed paper in inside the front cover. Open the top cover, and then reinstall paper roll

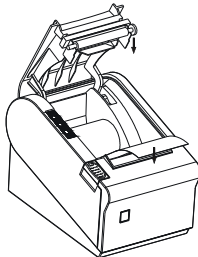

(Reinstall Paper Roll)

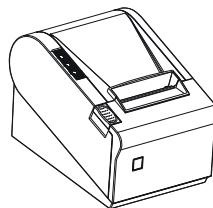

(Tear off the paper as shown)

# 6. Appendix

## 1. Product Specifications

### 1.1) Printing Specifications

- |                                   |  |
|-----------------------------------|--|
| 1. Printing method:               | Thermal line printing  |
| 2. Dot density:                   | 203 dpi×203 dpi.   |
| 3. Printing direction:            | Unidirectional with friction feed  |
| 4. Printing width:                | 72 mm (2.83"), 576 dot positions   |
| 5. Characters per line (default): | Font A: 48, English Font B: 24, Chinese  |
| 6. Character spacing (default):   | Font A: 0.25 mm (.01") (2 dots)  |
| 7. High speed mode:               | 220 mm/second, maximum (at 24V, 20C (68F), density level 2. Speeds are switc automatically depending on the voltage hed applied to the printer and head temperature conditions.) |

**NOTE:** *There may be variations in printing after switching the mode of the printing speed. To prevent this for logo printing with ESC command, using a downloaded bit image is recommended. Change in printing speed does not occur during down loaded bit image printing. Printing speed may be slower depending on the data transmission speed and the combination of control commands. Low transmission speed may cause intermittent printing. It is recommended to transmit data to the printer as quickly as possible.*

### 1.2) Auto Cutter

- |                 |                                   |
|-----------------|-----------------------------------|
| 1. Partial cut: | Cutting with one point left uncut |
|-----------------|-----------------------------------|

**NOTE:** *To prevent dot displacement, after cutting, paper must be fed approximately 1 mm (14/360 inches) or more before printing.*

### 1.3) Paper Roll Supply Device

- |                   |                    |
|-------------------|--------------------|
| 1. Supply method: | Drop-in paper roll |
|-------------------|--------------------|

## 1.4) Paper Specification

1. Paper type:	Specified thermal paper
2. Form:	Paper roll
3. Paper width:	79.5 ± 0.5 mm (3.13" ± 0.02")
4. Paper roll size:	Roll diameter: Maximum 83 mm
5. Specified paper:	Specified thermal roll paper; NTP080-80 Original paper: PD 160R (Oji Paper Mfg. Co. Ltd.) Original paper: AF50KS-E (Jujo Thermal Oy (Finland)) Original paper: P350 (F380), P310, P300
6. Paper roll spool diameter:	Inside: 12 mm (.47") Outside: 18 mm (.71")

**NOTE:** Paper must not be pasted to the paper roll spool.

## 1.5) Internal Buffer

1. Receive buffer useable 128K bytes.
2. User-defined buffer (both for user-defined characters and user-defined bit images): 12K bytes
3. NV Flash buffer: 256K bytes.

## 1.6) Electrical Characteristics

1. Supply voltage:	+24 VDC, 2.5A
2. Current consumption (at 24V):	High speed mode: Mean: Approximately 1.8A(Character font A -N, capital letters, 36-character rolling pattern, 42 columns printing) Peak: Approximately 8A Low power consumption mode: Mean: Approximately 1.2A Peak: Approximately 6.6 A Standby: Mean: Approximately 0.2A

**NOTE:** Maximum 1A for drawer kick-out driving.

## 1.7) Reliability

1. Life Span: Mechanism: 15,000,000 lines  
Thermal head: 100 million pulses, 100 Km  
Auto cutter: 1,500,000 cuts  
(End of life span is defined to have reached the end of its life when it reaches the beginning of the Wear out Period.)
2. MTBF: 360,000 hours  
(Failure is defined as Random Failure occurring at the time of the Random Failure Period.)
3. MCBF: 52,000,000 lines  
(This is an average failure interval based on failures relating to wear out and random failures up to the life of 15 million lines.)

## 1.8) Environmental Conditions

1. Temperature: Operating: 5 to 45C (41 to 113F)  
Storage: -10 to 50C (14 to 122F)  
(except paper)
2. Humidity: Operating: 10 to 90% RH  
Storage: 10 to 90% RH (except for paper)

*NOTE: If the printer is not used for a long time with paper installed, some part of the printing may be light due to the deformation of the paper. If the printer is not used for a long time with paper installed, be sure to feed paper approximately 30 mm before printing*

3. Acoustic noise (Operating): When using auto cutter Approximately 50 dB (Bystander position) When not using auto cutter: Approximately 40 dB (Bystander position)

## 1.9) Installation

The PRP-085III series printer must be installed horizontally. (Vibration during paper cutting and using a drawer should be considered. Take measures to prevent the printer from moving. Affixing tapes are provided as an option.) An optional hanging bracket can attach the printer to a wall. (Following the procedures describes in the installation manual, install the wall mount and change the location of the paper roll near-end sensor, then install the paper roll stopper and other parts.)

## 2. CONFIGURATION

### 2.1) Interface

#### a. RS-232 serial interface

##### a.1) RS-232 Specifications

- |                              |  |
|------------------------------|--|
| 1. Data transmission:        | Serial   |
| 2. Synchronization:          | Asynchronous   |
| 3. Handshaking:              | DTR/DSR or XON/XOFF control  |
| 4. Signal levels:            | MARK = -3 to -15 V: Logic "1"/ OFF<br>SPACE = +3 to +15 V: Logic "0"/ ON |
| 5. Baud rate:                | 9600, 19200, 38400, 115200 bps   |
| 6. Data word length:         | 8 bits   |
| 7. Parity Settings:          | None   |
| 8. Stop bits:                | 1 or more  |
| 9. Connector (printer side): | Female DSUB-25 pin connector   |

**NOTE:** The data word length, baud rate, and parity depend on the DIP switch settings.

The stop bit for the printer side is fixed to 1.

##### a.2) Serial interface connection example

Printer Side DB-25

POS RS-232 Connection DB9

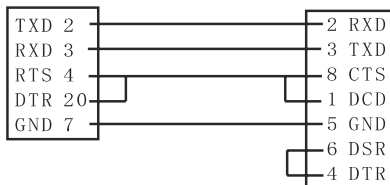

**NOTE:** Set the handshaking so that the transmit data can be received.  
Transmit data to the printer after turning on the power and initializing the printer.

**a.3) Interface connector terminal assignments and signal functions**

Pin number	Signal name	Signal source	Description
2	TXD	Printer	When using XON/XOFF handshake protocol, printer transmits control code XON/XOFF
3	RXD	Host	Printer receives data from host
4	RTS	Printer	Indicates printer current status, whether the printer is Busy or Ready to receive data
7	GND	---	Signal ground
20	DTR	Printer	Same as RTS (pin 4) °

**b. IEEE 1284 Bidirectional Parallel Interface (Parallel Interface Specifications)**

**b.1) Parallel Specifications**

- |                              |                                     |
|------------------------------|-------------------------------------|
| 1. Data transmission:        | Parallel                            |
| 2. Synchronization:          | Externally supplied nStrobe signals |
| 3. Handshaking:              | nAck and Busy signals               |
| 4. Signal levels:            | TTL compatible                      |
| 5. Data word length:         | 8 bits                              |
| 6. Connector (printer side): | 36 pins Centronics connector        |

## 2.2) Connectors

### a. Interface Connectors

Refer to Interface explanation.

### b. Power Supply Connector

This connector is used to connect the printer to an external power source.  
Power Supply Connector Pin Assignments

Pin Number	Signal Name
1	+24 VDC
2	GND
3	NC
Shell	Frame GND

### c. Drawer Kick-out Connector (Modular Connector)

The pulse specified by ESC p or DLE DC4 is output to this connector. The host can confirm the status of the input signal by using the DLE EOT, GS a, or GS r commands.

1. Pin assignments: Refer to Table
2. Connector model: Printer side: MOLEX 52065-6615 or RJ11 telephone jack  
User side: 6-position 6-contact (RJ11 telephone jack)

#### Drawer Kick-out Connector Pin Assignments

Pin Number	Signal Name	Direction
1	Frame GND	–
2	Drawer kick-out drive signal 1	Output
3	Drawer open/close signal	Input
4	+24V	–
5	Drawer kick-out drive signal 2	Output
6	Signal GND	–

## 2.2) Connectors

### a. Interface Connectors

Refer to Interface explanation.

### b. Power Supply Connector

This connector is used to connect the printer to an external power source.  
Power Supply Connector Pin Assignments

Pin Number	Signal Name
1	+24 VDC
2	GND
3	NC
Shell	Frame GND

### c. Drawer Kick-out Connector (Modular Connector)

The pulse specified by ESC p or DLE DC4 is output to this connector. The host can confirm the status of the input signal by using the DLE EOT, GS a, or GS r commands.

1. Pin assignments: Refer to Table
2. Connector model: Printer side: MOLEX 52065-6615 or RJ11 telephone jack  
User side: 6-position 6-contact (RJ11 telephone jack)

#### Drawer Kick-out Connector Pin Assignments

Pin Number	Signal Name	Direction
1	Frame GND	–
2	Drawer kick-out drive signal 1	Output
3	Drawer open/close signal	Input
4	+24V	–
5	Drawer kick-out drive signal 2	Output
6	Signal GND	–

### 3. Drawer kick-out drive signal

Output signal:      Output voltage: Approximately 24 V  
                            Output current: 1A or less

# General Printer Commands

## Command Lists:

Command	Function Description
HT	Horizontal tab
LF	Print and line feed
FF	Print and return to standard mode in page mode
CR	Print and carriage return
CAN	Cancel print data in page mode
DLE EOT n	Real-time status transmission
DLE ENQ n	Real-time request to printer
DLE DC4 n m t	Generate pulse at real-time
ESC FF	Print data in page mode
ESC SP n	Set right-side character spacing
ESC ! n	Select print mode(s)
ESC \$ nL nH	Set absolute print position
ESC % n	Select/cancel user-defined character set
ESC & y c1 c2 [x1 d1...d(y X x1)]...[xk d1...d(y X xk)]	Define user-defined characters
ESC * m nL nH d1...dk	Select bit-image mode
ESC - n	Turn underline mode on/off
ESC 2	Select default line spacing
ESC 3 n	Set line spacing
ESC = n	Set peripheral device
ESC ? n	Cancel user-defined characters
ESC @	Initialize printer
ESC D n1...nk nul	Set horizontal tab positions
ESC E n	Turn emphasized mode on/off
ESC G n	Turn double-strike mode on/off
ESC J n	Print and feed paper
ESC L	Select page mode
ESC M n	Select character font
ESC R n	Select an international character set
ESC S	Select standard mode
ESC T n	Select print direction in page mode
ESC V n	Turn 90° clockwise rotation mode on/off
ESC W xL xH yL yH dxL dxH dyL dyH	Set printing area in page mode
ESC \ nL nH	Set relative print position
ESC a n	Select justification
ESC c 5 n	Enable/disable panel buttons
ESC d n	Print and feed n lines
ESC p m t1 t2	General pulse
ESC t n	Select character code table

Command	Function Description
ESC { n	Turns on/off upside.down printing mode
FS p n m	Print NV bit image
FS q n [xL xH yL yH d1...dk]1...[xL xH yL yH d1 dk]n	Define NV bit image
GS ! n	Select character size
GS \$ nL nH	Set absolute vertical print position in page mode
GS* x y d1...d(x X y X 8)	Define downloaded bit image
GS / m	Print downloaded bit image
GS :	Start/end macro definition
GS B n	Turn white/black reverse printing mode
GS H n	Select printing position for HRI characters
GS L nL nH	Set left margin
GS P x y	Set horizontal and vertical motion units
GS V m / GS V m n	Select cut mode and cut paper
GS W nL nH	Set printing area width
GS \ nL nH	Set relative vertical print position in page mode
GS ^ r t m	Execute macro
GS f n	Select font for HRI characters
GS h n	Select barcode height
①GS k m d1...dk NUL ②GS k m n d1...dn	Print bar code
GS r n	Transmit status
GS v 0 m xL xH yL yH d1...dk	Print raster bit image
GS w n	Set barcode width
FS ! n	Set print mode(s) for Kanji characters
FS &	Select Kanji character mode
FS - n	Turn underline mode on/off for Kanji characters
FS .	Cancel Kanji character mode
FS 2 c1 c2 d1...dk	Define user-defined Kanji characters
FS S n1 n2	Set left- and right-side Kanji character spacing
FS W n	Turn quadruple-size mode on/off for Kanji characters

## Command classification

**Executing:** Printer executes the command, which does not then affect the following data.

**Setting:** Printer use flags to make setting and those setting affect the the followin data.

**Note:**

**Commands for International Fonts**

**ESC R n**                      Select an International Character Set [ Format ]  
 ASC II                            ESC                      R                      n  
    Hex                      1B                    52                    n  
    Decimal                27                    82                    n  
 [ Range ]                         $0 \leq n \leq 13$   
 [ Description ]                 Selects an international character set n from the following table:

n	Character set
0	U.S.A.
1	France
2	Germany
3	U.K.
4	Denmark I
5	Sweden
6	Italy
7	Spain I
8	Japan
9	Norway
10	Denmark II
11	Spain II
12	Latin America
13	Korea

[ Default ] n=0

**ESC t n**

Select character code table

[ Format ]

ASC II      ESC      t      n

Hex          1B          74      n

Decimal    27          116    n

[ Range ]

0 &lt;= n &lt;=10, 16&lt;= n &lt;=25

[ Description ]

Selects a page n from the character code table:

n	Page	Comment
0	PC437: [USA, Standard Europe]	
1	Katakana [Japanese]	
2	PC850 [Multilingual]	
3	PC860 [Portuguese]	
4	PC863 [Canadian-French]	
5	PC865 [Nordic]	
6	West Europe	
7	Greek	
8	Hebrew	
9	PC755 [Latvian/East Europe]	
10	Iran	
16	WPC1252	
17	PC866 [Cyrillic#2]	
18	PC852 [Latin2]	
19	PC858	
20	Iran II	
21	Latvian	
22	Arabic	
23	PT151,1251	
24	PC747	
25	WPC1257	
	Big 5 Chinese	Optional
	GB Chinese	Optional
	Korean	Optional
	Japanese Kanji (JIS)	Optional

[ Default ]    n=0

**Character code can also be selected by utility program**

1. To install the PRP-085III Default Code Page Setting utility, please insert the bundled CD disk into the CD-ROM drive.
2. In the CD menu, please go to Receipt Printer > PRP-085III>Code Page and double click the setup.exe file to begin the installation process and follow the installation instructions.
3. After installation is done, go to Program Files > CodePageSet > CodePageSet to start the utility.
4. For Serial interface connection, please select the proper COM port and baud rate which matches the current setting of the printer. For Parallel interface connection, select the proper LPT ports.

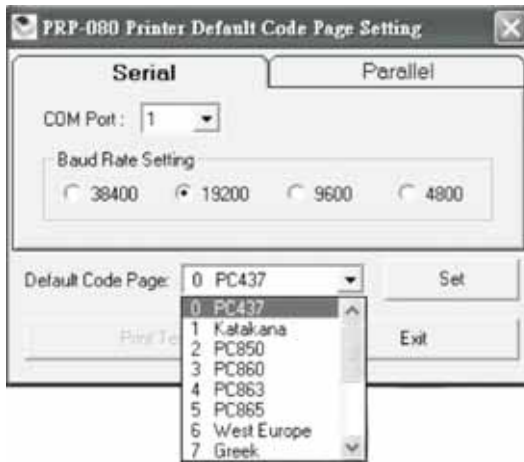

**Optional multilingual character model supports printing with one of the following characters:**

- a. B - Traditional Chinese (Big 5)
- b. G - Simplify Chinese (GB)
- c. K - Korean
- d. J- Japanese Kanji (JIS)

**To enable/disable the multilingual character code use the following commands: (\*)**

FS “&” Select Multilingual Character Mode ON  
[Format] ASCII FS &  
Hex 1C 26  
Decimal 28 38  
[Description] Enable multilingual character mode

-----

FS “.” Select Multilingual Character Mode OFF  
[Format] ASCII FS .  
Hex 1C 2E  
Decimal 28 46  
[Description] Disable multilingual character mode

(\*)Note: This command enable/disable the specific language according to the model (B, G, K or J)

